

# TM-11x1 Series Room Temperature Module

## Product Bulletin

Code No. LIT-12011543

Issued June 24, 2009

The TM-11x1 Series of Room Temperature Modules are designed for use with the TC-9102 Direct Digital Control (DDC) terminal unit controller. The setpoint dial enables the room occupant to adjust the working setpoint of the controller. On scaled models, the marked adjustment range is 55 to 85°F; the controller determines the actual setpoint. On Warmer/Cooler models, the adjustment range is marked +/- from the midpoint of the dial; the controller determines the equivalent setpoint temperature.

With the occupancy button, the occupant can switch the controller's operation mode between occupied and standby. In addition, the TM-11x1 Series offers the option of a temporary occupied mode during unoccupied mode.

The TM-11x1 Series Room Temperature Module also features a Light-Emitting Diode (LED) that indicates the current operating mode.



**Figure 1: TM-11x1 Series Room Temperature Modules**

For TC-9102 Fan Coil Unit controllers, a Room Temperature Module with a 3-speed fan override dial is available, and models without a temperature sensor are provided for applications where the room temperature sensor is mounted inside the Fan Coil Unit.

**Table 1: Features and Benefits**

Features	Benefits
Modern and Attractive Cover	Blends in with room decor.
Plug-in Mounting Base Snap-on Cover	Enables easy installation.
Mounting Base Terminals	Enable easy wiring and commissioning.
Optional Occupancy Override Button	Enables user to switch operating mode between occupied and standby, or request temporary occupied mode during unoccupied mode.
External LED Mode Indicator	Indicates the controller's current operating mode.
3-Speed Fan Override	Allows manual control of fan speed to ensure occupant comfort.
Optional Occupied Mode during Unoccupied Mode	Enables a temporary occupied mode using occupied setpoints during unoccupied mode.

## Application Overview

### Setpoint Dial

The TM-11x1 Series Room Temperature Module is available with a setpoint dial marked 55 to 85°F, or +/- for Warmer/Cooler models. The module must be connected to a controller with the corresponding remote setpoint range.

The 55 to 85°F range module determines the setpoint of the controller, whereas the +/- (5°F) range module provides a deviation to the room temperature setpoint programmed into the controller.

See Table 4 for Room Temperature Module ordering codes, and Table 5 for module accessories.

### Occupancy Button

When pressed for approximately 1 second, the occupancy button changes the controller's operation mode to the alternate mode or back to normal mode. For example, when the controller is in occupied mode, the alternate mode is standby (and vice versa). When the controller is in unoccupied mode, the alternate mode is a temporary occupied (bypass) mode that lasts for 1 hour.

For complete details of alternate modes, refer to the *TC-9102 Terminal Unit Technical Bulletin (LIT-6363050)*.

### LED Mode Indicator

The LED located directly next to the Occupancy Button indicates the current operating mode of the controller. Table 2 shows the operating modes reflected by the LED status.

**Table 2: Operating Modes**

LED Status	Mode
Steady On	Occupied
Flashing	Standby
Off	Unoccupied or Off

### 3-Speed Fan Override Dial

When connected to a TC-9102 controller that has a 3-speed fan control auxiliary output, the 3-speed fan override dial allows manual control of fan speed.

Table 3 describes the dial positions.

**Table 3: Dial Positions**

Position	Description
AUTO	Automatic fan speed is set by the TC-9102 controller.
OFF	Fan OFF
I	Fan low speed
II	Fan medium speed
III	Fan high speed

**Note:** The fan speed dial is active only when the controller is in occupied mode. In low limit mode, the fan always operates at high speed.

**Table 4: Ordering Codes for TM-11x1 Series Room Temperature Modules**

Code	Option			
	Fan Speed Override	Occupancy Button	Temperature Setpoint Dial Scale	Built-in Sensor
TM-1141-0000	---	---	---	NTC 2K2
TM-1151-0000	---	Yes	---	NTC 2K2
TM-1161-0000	---	Yes	55–85°F	NTC 2K2
TM-1161-0002	3-speed fan override	Yes	55–85°F	NTC 2K2
TM-1161-0005	---	Yes	None, ± (Warmer/Cooler)	NTC 2K2
TM-1161-0007	3-speed fan override	Yes	None, ± (Warmer/Cooler)	NTC 2K2
TM-1191-0000	---	---	55–85°F	NTC 2K2
TM-1191-0005	---	---	None, ± (Warmer/Cooler)	NTC 2K2

**Table 5: Ordering Codes for TM-11x1 Series Room Temperature Module Accessories**

Code	Description
T-4000-119 Allen-head Tool	1/16 in. (1.5 mm) Allen-head tool used to tighten/loosen cover security screw

### Mounting

Loosen the screw located at the top center of the module with the allen-head tool (ordering code

T-4000-119 in Table 5). Remove the housing from the base by inserting a screwdriver blade or coin into the slot on the top of the housing.

Press down gently, and pry the housing away from the base. As the two parts separate, remove the blade or coin and continue to pull the housing away from the base until the housing is free.

To reassemble the Room Temperature Module, place the housing over the lower edge of the base and push the upper part of the housing firmly in place until it clicks. Use the allen-head tool to tighten the screw located at the top center of the module.

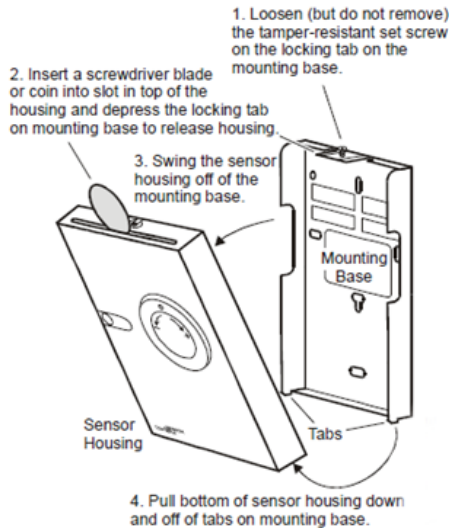

**Figure 2: Removing Cover from Base**

### Direct Surface Mounting

For direct surface mounting, mount the module base on the wall to cover the electrical outlet and secure the base with at least two screws (Figure 3):

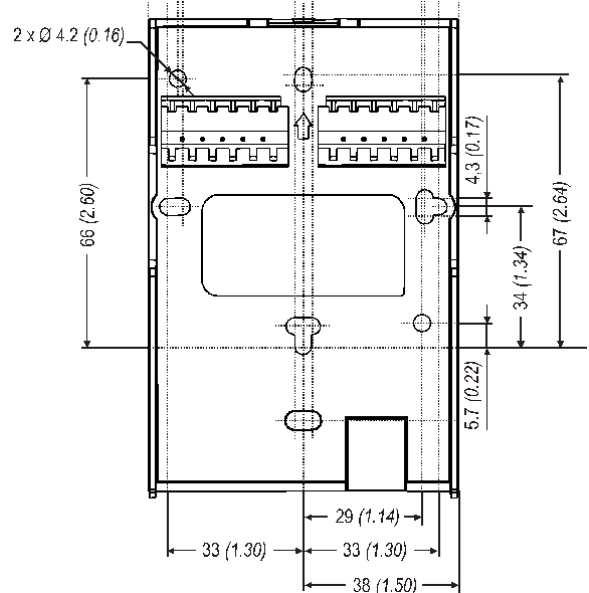

**Figure 3: Module Base Dimensions, in. (mm)**

### Wiring

Before connecting or disconnecting any wires, ensure that all power supplies have been switched off and all wires are potential-free to prevent equipment damage and avoid electric shock. Terminations are made on the terminal blocks in the base of the module and accept up to 16 AWG wires.

All wiring to the module is completed at an extra low (safe) voltage and must be separated from power line voltage wiring. Do not run wiring close to transformers or high frequency generating equipment. Complete and verify all wiring connections before applying power to the module's connected controller.

Follow Figure 4 through Figure 8 for safe wiring.

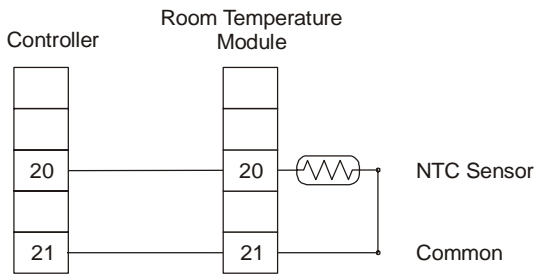

**Figure 4: TM-1141-0000 Wiring**

FIG:TM141\_WIR

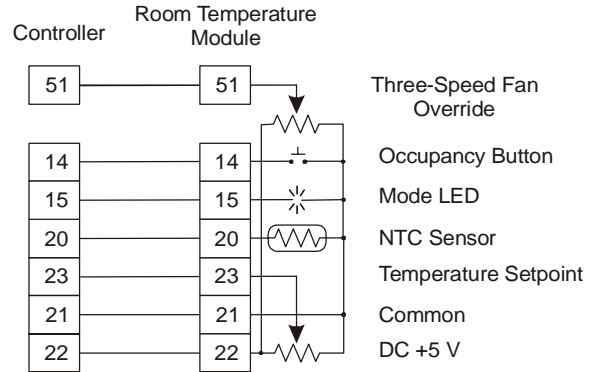

**Figure 7: TM-1161-0002 and TM-1161-0007 Wirings**

FIG:TM161\_WIR2

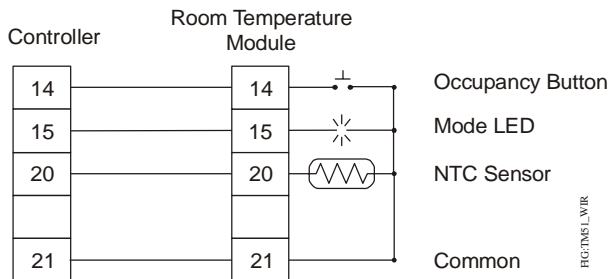

**Figure 5: TM-1151-0000 Wiring**

FIG:TM151\_WIR

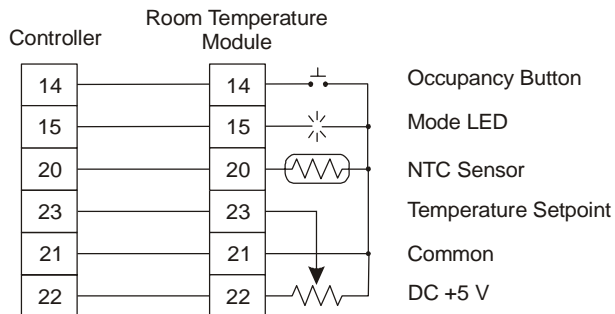

**Figure 6: TM-1161-0000 and TM-1161-0005 Wirings**

FIG:TM161\_WIR

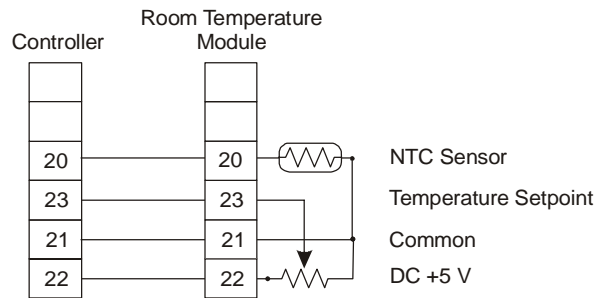

**Figure 8: TM-1191-0000 and TM-1191-0005 Wirings**

FIG:TM191\_WIR

## Dimensions

### TM-1141 Modules

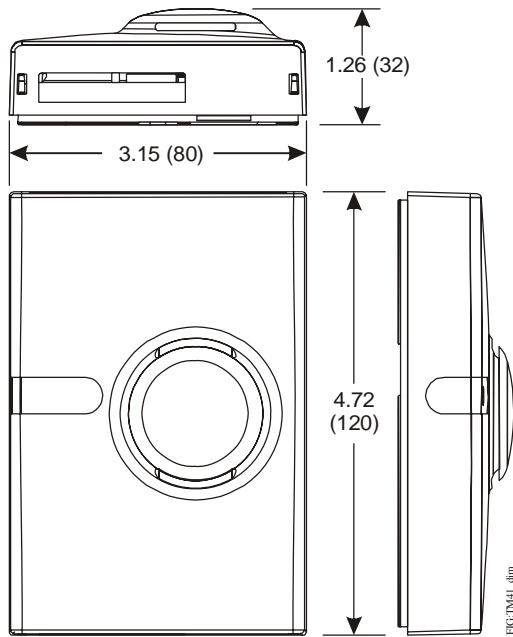

Figure 9: TM-1141 Dimensions, in. (mm)

### TM-1151 Modules

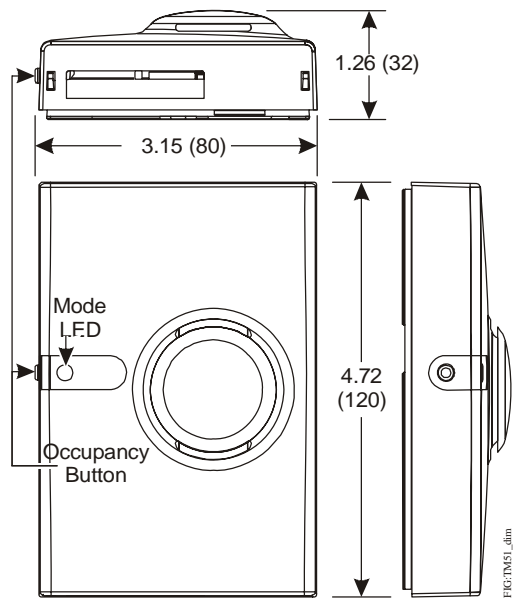

Figure 10: TM-1151 Dimensions, in. (mm)

### TM-1161 Modules

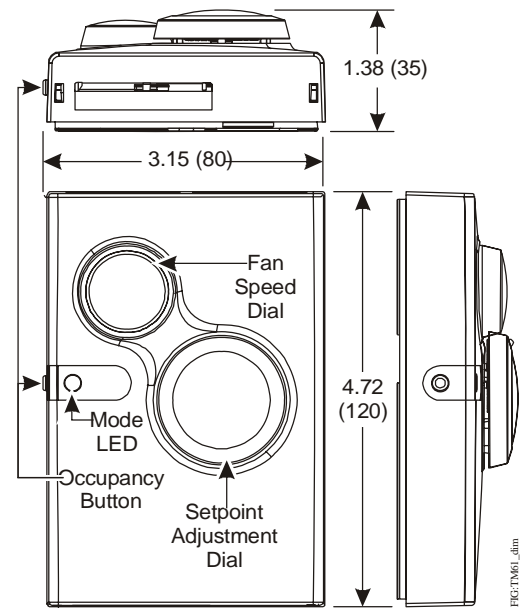

Figure 11: TM-1161-0002 and TM-1161-0007 Dimensions, in. (mm)

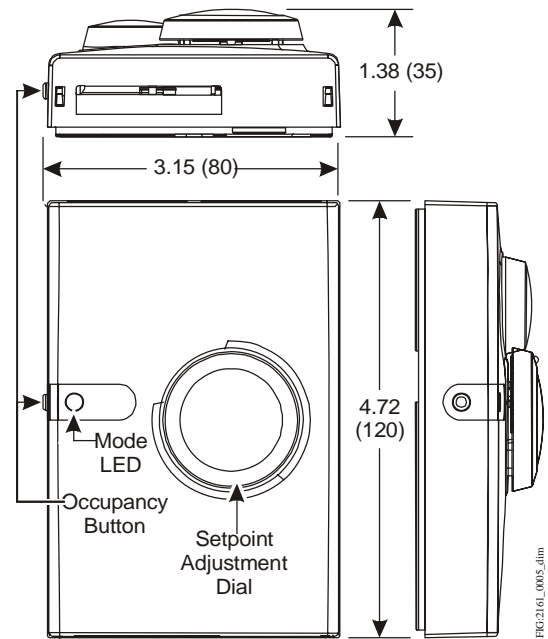

Figure 12: TM-1161-0000 and TM-1161-0005 Dimensions, in. (mm)

## TM-1191 Modules

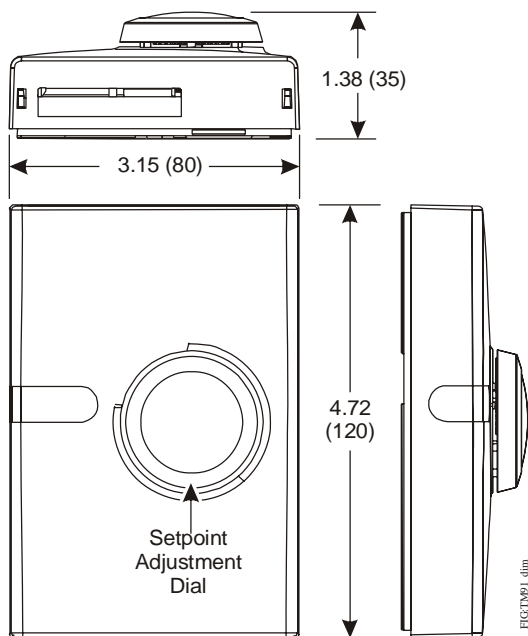

Figure 13: TM-1191 Dimensions, in. (mm)

## Repair Information

If the TM-11x1 Series Room Temperature Module fails to operate within its specifications, replace the unit. For a replacement TM-11x1 Series Module, contact the nearest Johnson Controls® representative.

## Technical Specifications

### TM-11x1 Series Room Temperature Module (Part 1 of 2)

<b>Supply Voltage</b>	Powered from the TC-9102 controller	
<b>Ambient Operating Conditions</b>	0 to 50°C (32 to 122°F) 10 to 90% RH noncondensing	
<b>Ambient Storage Conditions</b>	-40 to 70°C (-40 to 158°F) 5 to 95% RH noncondensing	
<b>Terminations</b>	Terminal block in base for 1 x 1.5 mm <sup>2</sup> (maximum) cable	
<b>Temperature Sensor</b>	NTC Thermistor 0 to 40°C (32 to 104°F), 2,252 ohm at 25°C (77°F)	
<b>Setpoint</b>	0–5 VDC via 10k ohm potentiometer marked for 55 to 85°F or +/- (5F°)	
<b>3-Speed Fan Override</b>	0–5 VDC via 10k ohm logarithmic potentiometer, detents at 0, 1.25, 2.50, 3.75, and 5.00 VDC corresponding to front cover markings for Auto, Off, I (low speed), II (medium speed), and III (high speed).	
<b>Occupancy Button</b>	Momentary contact (switches 5 V at 1 mA)	
<b>Mode Indicator</b>	Green LED (5 V, 4 mA)	
<b>Mounting</b>	Direct surface mount, plastic base for surface mount with wiring conduits. See Table 4.	
<b>Materials</b>	Enclosure Base Occupancy Override Button Fan Speed Override Dial Setpoint Dial	ABS+PC; self-extinguishing HB UL94

### TM-11x1 Series Room Temperature Module (Part 2 of 2)

<b>Colors</b>	Enclosure Base Occupancy Override Button Fan Speed Override Dial	RAL9016 (GE86280)
	Setpoint Dial	RAL7047 (GE GY81118)
<b>Protection Class</b>	Enclosure	IP30 (EN 60529)
<b>Dimensions (H x W x S)</b>	TM-1141-0000 TM-1151-0000	120 mm x 80 mm x 32 mm (4.72 in. x 3.15 in. x 1.26 in.)
	TM-1161-000x TM-1191-000x	120 mm x 80 mm x 35 mm (4.72 in. x 3.15 in. x 1.38 in.)
<b>Shipping Weight</b>	0.20 kg (0.44 lb)	
<b>Compliance</b>	EMC Directive 2004/108/EC	EN-61000-6-2



**Building Efficiency**  
507 E. Michigan Street, Milwaukee, WI 53202

*Metasys® and Johnson Controls® are registered trademarks of Johnson Controls, Inc.  
All other marks herein are the marks of their respective owners. © 2009 Johnson Controls, Inc.*