

RS-1100 Series Room Command Module

The RS-1100 series of electronic room temperature sensors and transducers provide a passive or active signal that corresponds to the room temperature in heating, ventilating and air conditioning applications.

They provide a 0...10V signal directly proportional to the sensed temperature.

The RS-1100 series is primarily designed to be used as input to a digital controller of the system 9100 family but can be used with other electronic devices.



RS-1140



RS-1190



RS-1160

Features and Benefits

- | | |
|--|--|
| <input type="checkbox"/> Modern and attractive cover which snaps onto a plug-in mounting base | Blends in with room decor.
Easy installation. |
| <input type="checkbox"/> Terminals located on mounting base. | Easy wiring and commissioning. |
| <input type="checkbox"/> Active output | Covers a large number of applications. |
| <input type="checkbox"/> All models available with or without occupancy override | Covers a large number of applications in public buildings and hotels |

Application Overview

The RS-1100 series of electronic room temperature sensors and transducers provide a 0...10 V signal directly proportional to the sensed temperature.

The various RS-1100 versions can be connected to the controllers of the system 9100 series (see table below), but can also be used with other electronic devices.

The 0...10 V DC room temperature transducers receive a +15 V DC supply voltage, available from the system 9100 controllers.

Set Point Dial

Models with a set point dial marked 12°C to 28°C or ± can be used with the TC-9100 "Universal", the SC-9100 "Easy DDC" and the DR/DC/DX - 9100 controllers. The 12°C to 28°C range determines the set point of the controller and the ± gives a deviation of max. 3K to the room temperature set point programmed into the controller.

Occupancy Button

Models with a comfort/standby push-button can only be used with system 9100 controllers as per table 1. Pressing the button will change the mode of operation of the controller from the "comfort" set point to the "stand-by" or "off" set point.

Mode Indicator

The LED indicator next to the Occupancy Button shows the current operating mode of the controllers as follows:

Steady On: COMFORT Mode (Occupied);

Flashing: STANDBY Mode;

Off: NIGHT or OFF Mode (Scheduled unoccupied or not in use).

Please refer to the appropriate table in the controller technical bulletins for a detailed description of mode selection.

Ordering Data

Ordering code	User Interface		Applications		
	Setpoint Adjustment Dial Range	Comfort/Standby push button	TC-9100	SC-9100	DC-9100, DX-9100 or other electronic devices with 0/10V inputs
RS-1140-0000	no	-	yes	yes	yes
RS-1160-0000	12/28°C	yes	yes	-	-
RS-1160-0005	±	yes	yes	-	-
RS-1190-0000	12/28°C	-	yes	yes	yes
RS-1190-0005	±	-	yes	yes	yes

Table: 1

Accessories (order separately)

Order Code	Description
TM-1100-8931	Plastic surface mounting kit
TM-9100-8900	Special tool for opening enclosure

Mounting

The RS-1100 room sensors are suitable for direct wall-mounting using two of the four screw holes on the base (See Basic Models figure 10). They may also be mounted by using the mounting kit shown. The wiring must be entered from the back.

For mounting follow the instructions below:

- Choose an appropriate place to achieve good control of the ambient temperature. The room temperature element only senses the temperature at the place where it is mounted.
- When mounting ensure that there is sufficient space for air circulation but do not mount the sensor near windows or doors so as to avoid draughts that will falsify measurements.
- Put insulation material in the wiring conduit to prevent introduction of air from outside the room.
- The sensor should not be exposed to direct radiation (lamps, radiators, etc.) or to the sun, as this would lead to incorrect measurement.

Direct Surface Mounting

For direct surface mounting:

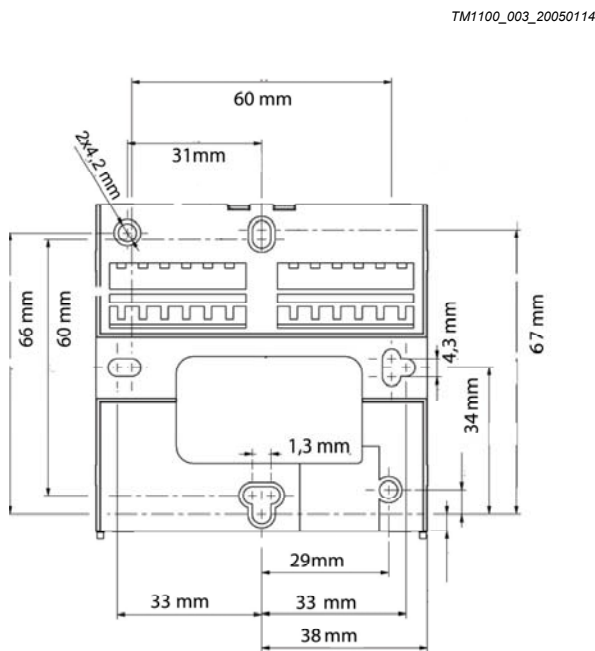
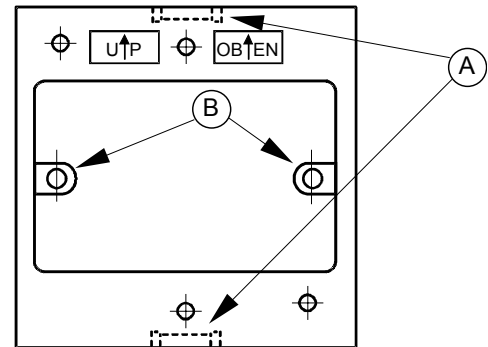

Figure 1: Module Base (Dimensions in mm)

1. Mount the module base on the wall to cover the electrical outlet and secure with at least two screws.

Surface Mounting with Mounting Kit (TM-1100-8931)



1. Remove one of the notches (A) with a suitable tool.
2. Mark the position of the holes (B) on the wall and drill holes 5 mm in diameter. Insert plastic plugs into holes.

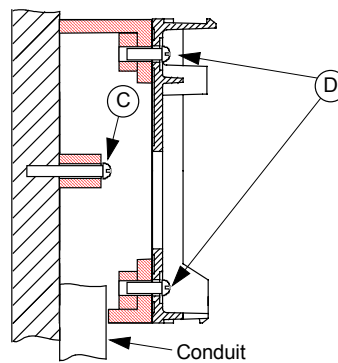

3. Position and fix the mounting base to the wall using the two long screws (C) provided in the kit.
4. Fix the base of the TM-1100 to the mounting base using the two short screws (D) provided in the kit.

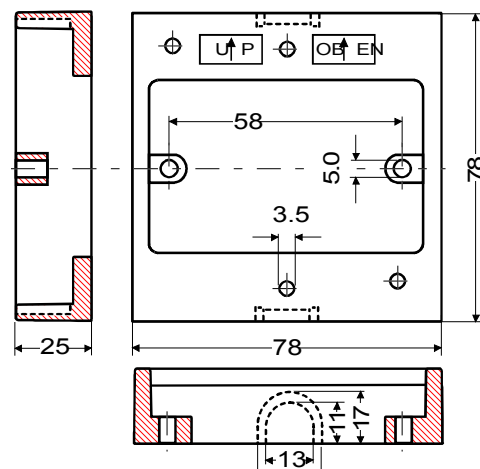

Figure 2: Surface Mounting Base (Dimensions in mm)

Wiring

For wiring follow the instructions below:

- All wiring must be in accordance with local regulations and national rules.
- Do not attempt field repairs. If the transmitter is not operating properly, even though it is wired correctly, it should be replaced

⚠ WARNING

When wiring or servicing make sure that:

- the electric voltage to the sensor is switched off to avoid possible damage to the equipment, personal injury or shock.
- you do not touch or attempt to connect or disconnect wires when electric power is on.

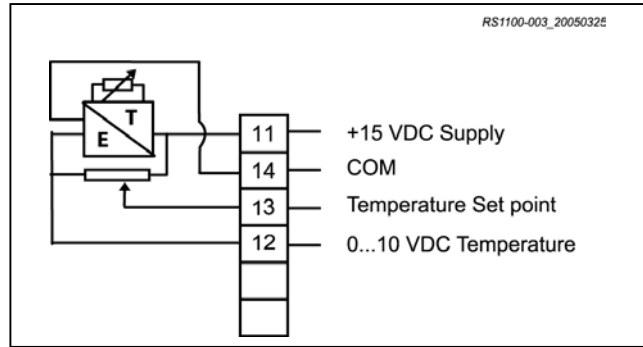

Figure 5: RS-1190-0000 and RS-1190-0005

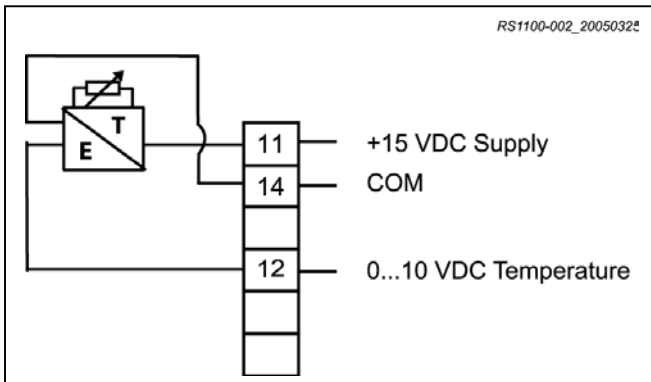

Figure 3: RS-1140-0000

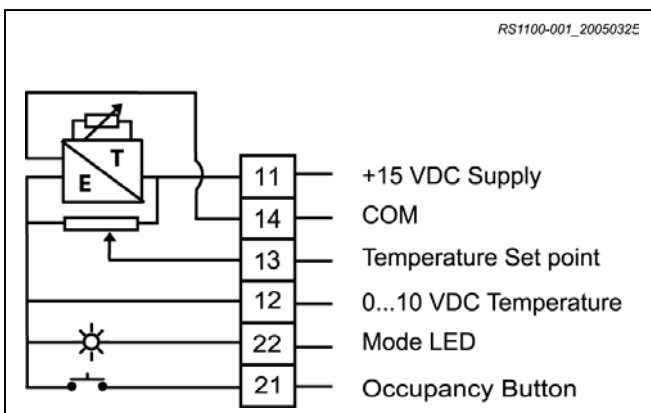

Figure 4: RS-1160-0000 and RS-1160-0005

Dimensions and Printings

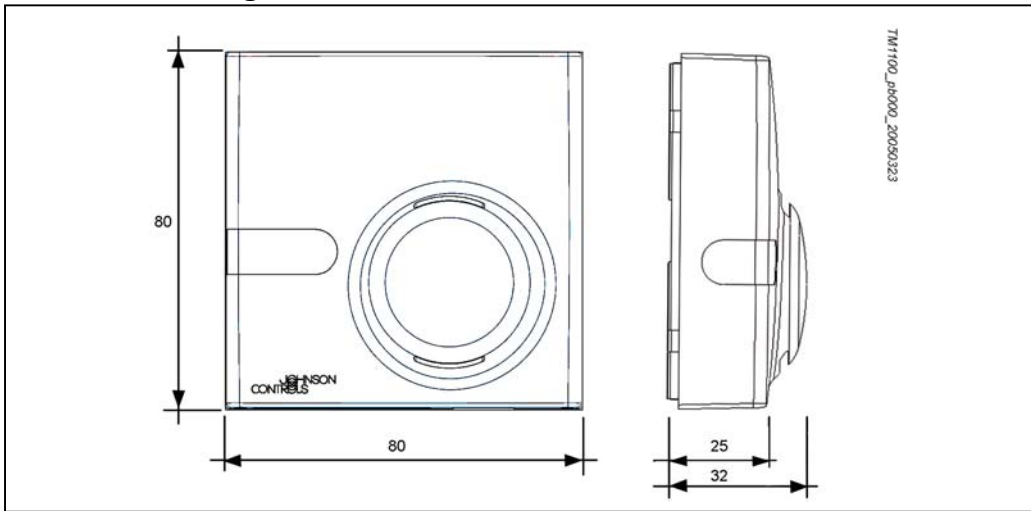

Figure 5: RS-1140-0000

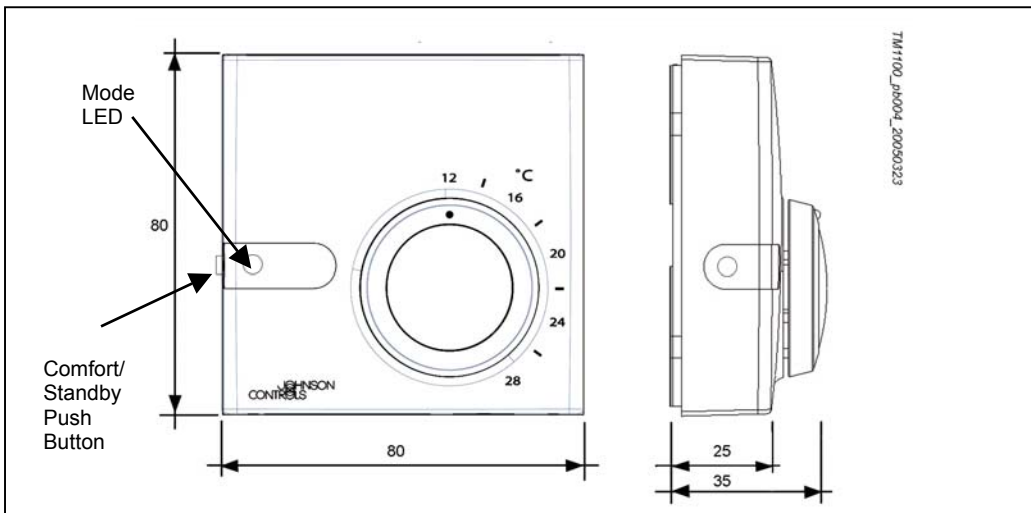

Figure 6: RS-1160-0000

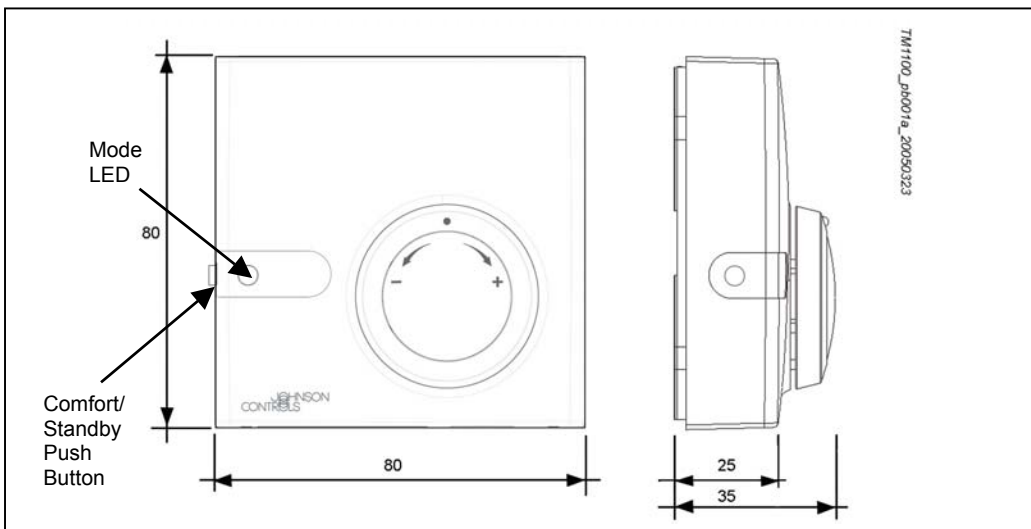

Figure 7: RS-1160-0005

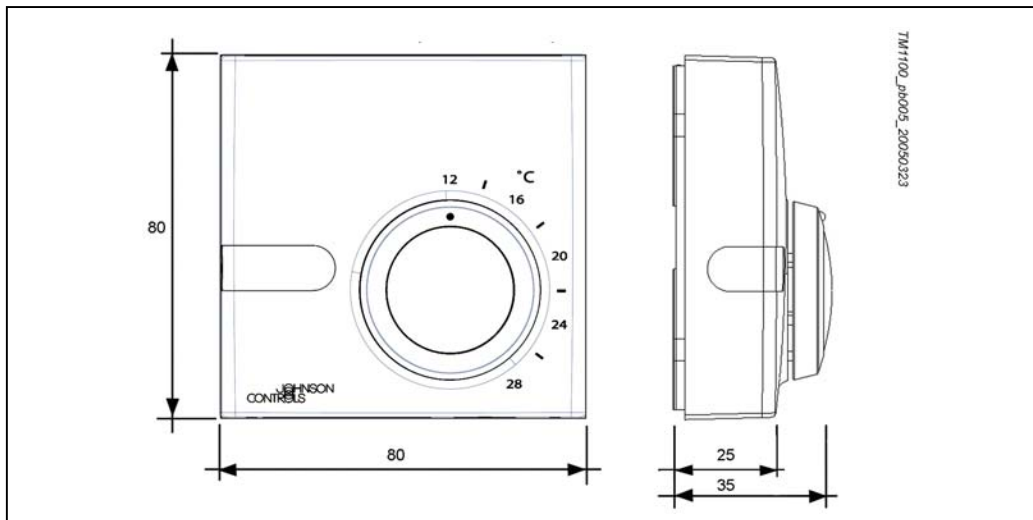

Figure 8: RS-1190-0000

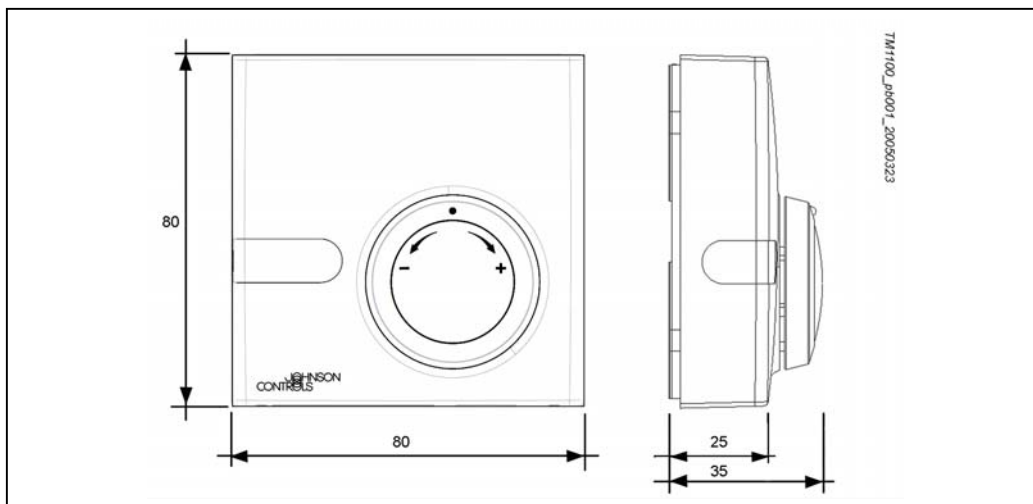

Figure 9: RS-1190-0005

Specifications

Sensing Element	Pt1000 class B, EN 60751	
Supply Voltage	15 Vdc \pm 5 %	
Power Consumption	7 mA, no load 9.5 mA, max load	
Output signal for temp.	Active 0...10 V DC linear 0 V \equiv 0°C 10 V \equiv 40°C	
Output load	min. 5 k Ω , max. 2mA	
Accuracy	1.2 % from 10 to 30°C 3.5 % from 0 to 10°C and 30 to 40°C	
Set Point Adjustment	limited 0...10 V signal linear (actual range 3 to 7 V)	
Mode Selector	momentary contact switch (5 V at 1 mA)	
Mode Indicator	green LED (5 V, 4 mA)	
Terminations	Screw terminal box mounted on base for 1 x 1,5 mm ² / 14 AWG (maximum) cable	
Mounting	Direct surface mounting. See in addition the mounting kit for surface	
Materials	Enclosure	ABS+PC; self extinguishing UL 94 HB
	Base	
	Occupancy Override Button	
	Setpoint Dial	
Colors	Enclosure	RAL9016 (GE86280)
	Base	
	Occupancy Override Button	RAL7047 (GE GY81118)
	Setpoint Dial	
Protection Class	Enclosure	IP30 (EN 60529)
Dimension (H x W x D)	RS-1140-0000	80 mm x 80 mm x 32 mm
	RS-1160-000x	80 mm x 80 mm x 35 mm
	RS-1190-000x	
Shipping Weight	0,15 kg	
CE Conformity	EMC Directive 89 / 336 EU	EN-61000-6-3
		EN-61000-6-2

The performance specifications are nominal and conform to acceptable industry standards. For application at conditions beyond these specifications, consult the local Johnson Controls office. Johnson Controls, Inc. shall not be liable for damages resulting from misapplication or misuse of its products.



Johnson Controls International, Inc.

Headquarters:
European Distribution Centre:
European Factories:
Branch Offices

Milwaukee, Wisconsin, USA
Westendhof 3, D-45143 Essen, Germany
Essen (Germany), Leeuwarden (The Netherlands) and Lomagna (Italy)
Principal European Cities.